

PRODUCT BULLETIN



Eastern US
30625 Solon Industrial Pkwy
Solon, OH 44139
Tel: (440) 542-3720
Fax: (440) 542-3721

Western US & Mexico
3453 Durahart Street
Riverside, CA 92507
Tel: (951) 369-0878
Fax: (951) 369-8281

Canada & International
35 Elgin Street, North
Thornbury, ON N0H 2P0
Tel: (519) 599-2015
Fax: (519) 599-6803

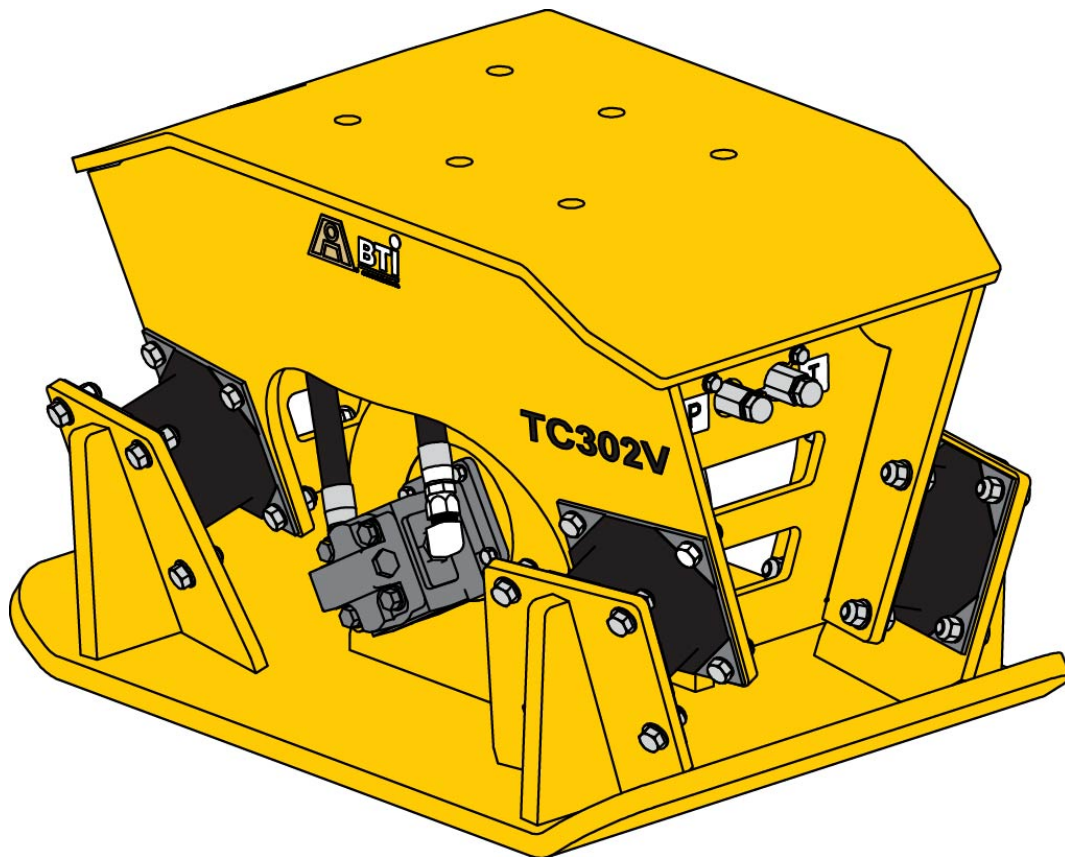

TC302V Hydraulic Compactor

www.rockbreaker.com

FEATURES and BENEFITS

- High Performance, Low Maintenance: The hydraulic motor is sized for high flow and low pressure to match the auxiliary hydraulic circuit of back hoes and mini excavators, reducing heat generation. Standard flow control valve protects the rotating group from over-speeding, ensuring optimum operating speeds by returning excess flow to the tank.
- High amplitude, high frequency operation and high ground pressure are standard to achieve maximum proctor densities and high lifts.
- Internal anti-cavitation valves permit the hydraulic motor to slow down safely after shutting off the control valve, eliminating shock loading to the rotating group.
- Maintenance free, oil bath lubrication ensures continuous bearing lubrication and eliminates the need for manual greasing.
- Oversized rubber isolators reduce vibration in the upper structure, delivering maximum energy through the base plate and into the soil, providing excellent proctor densities.
- Utilizing "Vector" Technology, Rubber isolators are mounted on compound angles allowing the isolators to better resist the down force produced by the carrier as well as the push / pull force of the carrier when compacting large areas.
- Mounting brackets are available with fixed, dedicated OEM pin centers to meet most interface requirements. Various quick coupler models are also available.

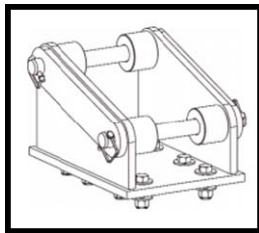

Non-Swivel

SPECIFICATIONS

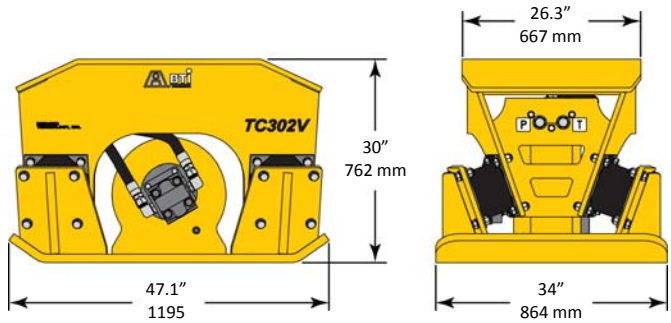

Specifications		TC302V-L	TC302V-H
Recommended Carrier Weight	lbs	33,000-77,000	
	kg	15,000-35,000	
Operating Weight (1)	lbs	2,045	2,050
	kg	930	932
Impulse Force	lbs	16,330-24,400	
	kg	7,423-11,091	
Ground Pressure	psi	13.4-20	
	bar	0.92-1.38	
Oil Flow Range (2)	gpm	37-58	53-80
	lpm	140-220	200-302
RPM Range		1,800-2,200	
Maximum Relief Valve Setting	psi	3,625	
	bar	250	

(1) Approximate weight may differ due to mounting configurations.

(2) Regulated flow is 46 gpm (174 lpm) for the TC302V-L and 65 gpm (246 lpm) for the TC302V-H. Adjust carrier flow as closely as possible to these values to reduce the potential for hydraulic system overheating.

All dimensions and specifications are approximate and subject to change without notice.

TC302V Hydraulic Compactor

REPLACEMENT PARTS COMPARISON CHART

Replacement Part	Part Number (Qty.)			
	TC301-L (old model)	TC302V-L (new model)	TC301-H (old model)	TC302V-H (new model)
Hydraulic Motor	1010710 (1)	1010710 (1)	1010711 (1)	1010711 (1)
Hydraulic Motor Seal Kit	380-0110 (1)	380-0110 (1)	390-0110 (1)	390-0110 (1)
Hydraulic Motor Mount Seal	1800947 (1)	1017663 (1)	1800947 (1)	1017663 (1)
Bearing	1006886 (2)	1006886 (2)	1006886 (2)	1006886 (2)
Bearing Housing Seal	1801855 (2)	1800949 (1)	1801855 (2)	1800949 (1)
Rubber Isolator	1007828 (4)	1007828 (4)	1007828 (4)	1007828 (4)

TC302V Hydraulic Compactor

www.rockbreaker.com